

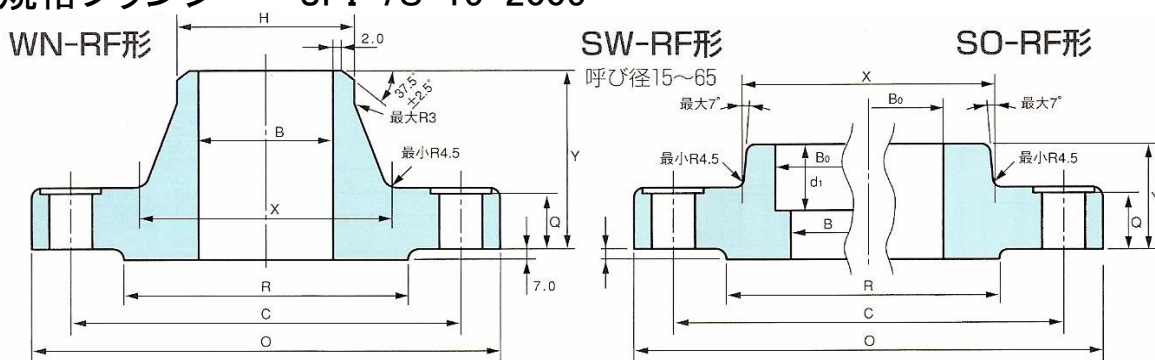

■ JPI規格フランジ JPI-7S-15-2005



ガスケット面仕上げは、JPI規格では中心線平均粗さの区分値でクラス400以上は3.2Ra。ASME規格では全クラス共通で125-500uin.(半径1.6mmの円形先端を持つ切削バイトで歩み1.0-0.6mm、深さ0.08-0.03mmのU字形のミゾを渦巻き状または同心円状に切る。1インチ当たり24-40ミゾ)

クラス400 PN65

単位：mm

呼び径		JPI規格						ASME規格 (参考)						JPI規格				
		SO SW内径	L A P内径	SW,WN内径			ハブ先の径	SO SW内径	L A P内径	SW,WN内径			ハブ先の径	外径	ハブ元の径	座径	厚み(最小)	隅の半径
				S40	S80	S160				STD	XS	XXS						
A	B	B ₀	B ₁	B			H	B ₀	B ₁	B			H	O	X	R	Q	r ₁
呼び径15~90まではクラス600と同じ																		
100	4	115.4	116.9	102.3	97.1	87.3	114.3	116.1	116.8	102.3	97.2	80.1	114.3	255	146	157.2	35.0	11
(125)	5	141.2	143.0	126.6	120.8	108.0	139.8	143.8	144.4	128.2	122.3	103.2	141.3	280	178	185.7	38.1	11
150	6	166.6	168.4	151.0	143.2	128.8	165.2	170.7	171.4	154.1	146.3	124.4	168.3	320	206	215.9	41.3	13
200	8	218.0	219.5	199.9	190.9	170.3	216.3	221.5	222.2	202.7	193.7	174.6	219.1	380	260	269.9	47.7	13
250	10	269.5	271.7	248.8	237.2	210.2	267.4	276.2	277.4	254.9	247.6	-	273.0	445	321	323.8	54.0	13
300	12	321.0	322.8	297.9	283.7	251.9	318.5	327.0	328.2	304.8	298.4	-	323.8	520	375	381.0	57.2	13
350	14	358.1	360.2	333.4	317.6	284.2	355.6	359.2	360.2	336.6	330.2	-	355.6	585	425	412.8	60.4	13
400	16	409.0	411.2	381.0	363.6	325.4	406.4	410.5	411.2	387.4	381.0	-	406.4	650	483	469.9	63.5	13
450	18	460.0	462.3	428.6	409.6	366.8	457.2	461.8	462.3	438.2	431.8	-	457.0	710	533	533.4	66.7	13
500	20	511.0	514.4	477.8	455.6	-	508.0	513.1	514.4	489.0	482.6	-	508.0	775	587	584.2	69.9	13
550	22	564.4	-	527.0	501.6	-	558.8	-	-	-	-	-	-	838	641	641.4	73.2	-
600	24	613.0	616.0	574.6	547.6	-	609.6	616.0	616.0	590.6	584.2	-	616.0	915	702	692.2	76.2	13

クラス600 PN110

単位：mm

呼び径		JPI規格						ASME規格 (参考)						JPI規格				
		SO SW内径	L A P内径	SW,WN内径		ハブ先の径	SO SW内径	L A P内径	SW,WN内径		ハブ先の径	外径	ハブ元の径	座径	厚み(最小)	隅の半径		
				S80	S160				XS	XXS								
A	B	B ₀	B ₁	B		H	B ₀	B ₁	B		H	O	X	R	Q	r ₁		
15	1/2	22.2	23.4	14.3	12.3	21.7	22.2	22.9	13.8	6.5	21.3	95	38	34.9	14.3	3		
20	3/4	27.7	28.9	19.4	16.2	27.2	27.7	28.2	18.9	11.1	26.7	115	48	42.9	15.9	3		
25	1	34.5	35.6	25.0	21.2	34.0	34.5	34.9	24.3	15.2	33.4	125	54	50.8	17.5	3		
(32)	1 1/4	43.2	44.3	32.9	29.9	42.7	43.2	43.7	32.5	22.8	42.2	135	64	63.5	20.0	5		
40	1 1/2	49.1	50.4	38.4	34.4	48.6	49.5	50.0	38.1	28.0	48.3	155	70	73.0	22.3	6		
50	2	61.1	62.7	49.5	43.1	60.5	61.9	62.5	49.2	38.3	60.3	165	84	92.1	25.4	8		
65	2 1/2	77.1	78.7	62.3	57.3	76.3	74.6	75.4	59.0	45.1	73.0	190	100	104.8	28.6	8		
80	3	90.0	91.6	73.9	66.9	89.1	90.7	91.4	73.7	58.4	88.9	210	117	127.0	31.8	10		
(90)	3 1/2	102.6	104.1	85.4	76.2	101.6	103.4	104.1	85.4	69.3	101.6	230	133	139.7	35.0	10		
100	4	115.4	116.9	97.1	87.3	114.3	116.1	116.8	97.2	80.1	114.3	275	152	157.2	38.1	11		
(125)	5	141.2	143.0	120.8	108.0	139.8	143.8	144.4	122.3	103.2	141.3	330	189	185.7	44.5	11		
150	6	166.6	168.4	143.2	128.8	165.2	170.7	171.4	146.3	124.4	168.3	355	222	215.9	47.7	13		
200	8	218.0	219.5	190.9	170.3	216.3	221.5	222.2	193.7	174.6	219.1	420	273	269.9	55.6	13		
250	10	269.5	271.7	237.2	210.2	267.4	276.2	277.4	247.6	-	273.0	510	343	323.8	63.5	13		
300	12	321.0	322.8	283.7	251.9	318.5	327.0	328.2	289.4	-	323.8	560	400	381.0	66.7	13		
350	14	358.1	360.2	317.6	284.2	355.6	359.2	360.2	330.2	-	355.6	605	432	412.8	69.9	13		
400	16	409.0	411.2	363.6	325.4	406.4	410.5	411.2	381.0	-	406.4	685	495	469.9	76.2	13		
450	18	460.0	462.3	409.6	366.8	457.2	461.8	462.3	431.8	-	457.0	745	546	533.4	82.6	13		
500	20	511.0	514.4	455.6	408.0	508.0	513.1	514.4	482.6	-	508.0	815	610	584.2	88.9	13		
550	22	564.4	-	501.6	450.8	558.8	-	-	-	-	-	870	667	641.4	95.3	-		
600	24	613.0	616.0	547.6	490.6	609.6	616.0	616.0	584.2	-	610.0	940	718	692.2	101.6	13		

備考 1. SW, WN形の内径寸法 (B) は、注文者の指定による。
2. SW, WNの重量はスケジュール80の場合を示す。

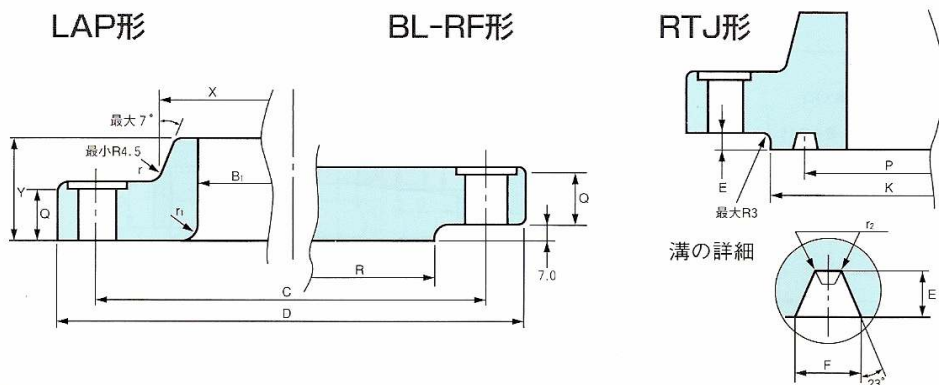

参考

ボルト穴径のJPIとASME規格との相違は下表の通り			
JPI	16	19	22
ASME	15.8	19.1	22.4
JPI	26	29	32
ASME	25.4	28.5	31.8
JPI	35	39	42
ASME	35.1	38.1	41.2
JPI	45	48	51
ASME	44.5	47.8	50.8
JPI	54	61	67
ASME	53.9	60.5	66.6
JPI	74	80	93
ASME	73.2	79.2	91.9

クラス400 PN65

単位：mm

J P I 規格													重 量 (kg)			呼び径	
全長			ソケット 深さ	ボルト穴			リングジョイント座						WN	SO	BL	A	B
LAP	SO	WN		中心径	数	径	座径 (最小)	中心径	リング 番号	深	幅	隅の半径					
Y			d ₁	C		K	P		E	F	r ₂						
呼び径15~90まではクラス600と同じ																	
51	51	89	-	200.0	8	26	175	149.23	R37	7.92	11.91	0.8	13.7	11.3	14.0	100	4
54	54	102	-	235.0	8	26	210	180.98	R41	7.92	11.91	0.8	18.2	14.2	18.6	(125)	5
57	57	103	-	269.9	12	26	241	211.12	R45	7.92	11.91	0.8	24.3	18.9	25.8	150	6
68	68	117	-	330.0	12	29	302	269.88	R49	7.92	11.91	0.8	38.2	29.3	42.8	200	8
102	73	124	-	387.4	16	32	356	323.85	R53	7.92	11.91	0.8	54.0	40.7	64.0	250	10
108	79	137	-	450.8	16	35	413	381.00	R57	7.92	11.91	0.8	79.0	59.0	95.0	300	12
117	84	149	-	514.4	20	35	457	419.10	R61	7.92	11.91	0.8	107.0	80.0	125.0	350	14
127	94	152	-	571.5	20	39	508	469.90	R65	7.92	11.91	0.8	136.0	103.0	163.0	400	16
137	98	165	-	628.6	24	39	575	533.40	R69	7.92	11.91	0.8	169.0	123.0	205.0	450	18
146	102	168	-	685.8	24	42	635	584.20	R73	9.52	13.49	1.5	205.0	148.0	255.0	500	20
-	108	171.4	-	743.0	24	45	686	635.00	R81	11.13	15.09	1.5	219.0	176.0	314.0	550	22
159	114	175	-	812.8	24	48	749	692.15	R77	11.13	16.66	1.5	301.0	222.0	388.0	600	24

クラス600 PN110

J P I 規格													重 量 (kg)			呼び径	
全長			ソケット 深さ	ボルト穴			リングジョイント座						WN	SO	BL	A	B
LAP	SO	WN		中心径	数	径	座径 (最小)	中心径	リング 番号	深	幅	隅の半径					
Y			d ₁	C		K	P		E	F	r ₂						
22	22	52	10	66.7	4	16	51.0	34.14	R11	5.56	7.14	0.8	0.88	0.74	0.76	15	1/2
25	25	57	11	82.6	4	19	63.5	42.88	R13	6.35	8.74	0.8	1.46	1.26	1.28	20	3/4
27	27	62	13	88.9	4	19	70.0	50.80	R16	6.35	8.74	0.8	1.87	1.56	1.65	25	1
29	29	67	14	98.4	4	19	79.5	60.33	R18	6.35	8.74	0.8	2.52	2.04	2.26	(32)	1 1/4
32	32	70	16	114.3	4	22	90.5	68.27	R20	6.35	8.74	0.8	3.54	2.98	3.28	40	1 1/2
37	37	73	17	127.0	8	19	108	82.55	R23	7.92	11.91	0.8	4.40	3.65	4.16	50	2
41	41	79	19	149.2	8	22	127	101.60	R26	7.92	11.91	0.8	6.33	5.11	6.09	65	2 1/2
46	46	83	21	168.3	8	22	147	128.83	R31	7.92	11.91	0.8	8.69	7.11	8.57	80	3
49	49	86	-	184.2	8	26	159	131.78	R34	7.92	11.91	0.8	11.0	9.0	11.2	(90)	3 1/2
54	54	102	-	215.9	8	26	175	149.23	R37	7.92	11.91	0.8	17.7	14.7	17.5	100	4
60	60	114	-	266.7	8	29	210	180.98	R41	7.92	11.91	0.8	29.5	24.6	29.4	(125)	5
67	67	117	-	292.1	12	29	241	211.12	R45	7.92	11.91	0.8	35.7	29.5	36.4	150	6
76	76	133	-	349.2	12	32	302	269.88	R49	7.92	11.91	0.8	55	44.2	59	200	8
111	86	152	-	431.8	16	35	356	323.85	R53	7.92	11.91	0.8	91	73	98	250	10
117	92	156	-	489.0	20	35	413	381.00	R57	7.92	11.91	0.8	110	87	125	300	12
127	94	165	-	527.0	20	39	457	419.10	R61	7.92	11.91	0.8	131	100	152	350	14
140	106	178	-	603.2	20	42	508	469.90	R65	7.92	11.91	0.8	184	137	214	400	16
152	117	184	-	654.0	20	45	575	533.40	R69	7.92	11.91	0.8	226	175	275	450	18
165	127	190	-	723.9	24	45	635	584.20	R73	9.52	13.49	1.5	284	223	351	500	20
-	133	196.8	-	777.7	24	48	686	635.00	R81	11.13	15.09	1.5	306	258	429	550	22
184	140	203	-	838.2	24	51	749	692.15	R77	11.13	16.66	1.5	408	316	535	600	24